

UNIT : mm
 UNLESS OTHERWISE SPECIFIED
 ASSY LENGTH TOLERANCE
 < 150mm = ±10
 ≥ 150mm and < 250mm = ±15
 ≥ 250mm and < 500mm = ±20
 ≥ 500mm and < 1000mm = ±30
 ≥ 1000mm and < 5000mm = ±50
 5000mm and above = ±100

RoHS COMPLIANT

This document is the property of Alysium-Tech. It must not be copied or otherwise disclosed without prior written consent



BILL OF MATERIALS

Item	Description
1.	A+ RJ45 Cat6A Unified DC(OD6.6) V2 Diecast Metal Shell
2.	A06-5893, [OD=6.6mm] <BLK> E357566 ALY-C UL21814 Halogen Free CAT7 4STP#26, Dual Shielded with LSZH TPU Jacket
3	Accessories (Please refer to Accessories Details):

TEST SPECIFICATION

Electrical Test (Continuity, Insulation Resistance, Conductance Test)

For Assembly Length < 20m

- 1) Voltage = 300VDC,
- 2) Insulation Resistance = 20MΩ
- 3) Conductance = 3Ω

For Assembly Length ≥ 20m

- 1) Voltage = 500VDC,
- 2) Insulation Resistance = 20MΩ
- 3) Conductance = 5Ω

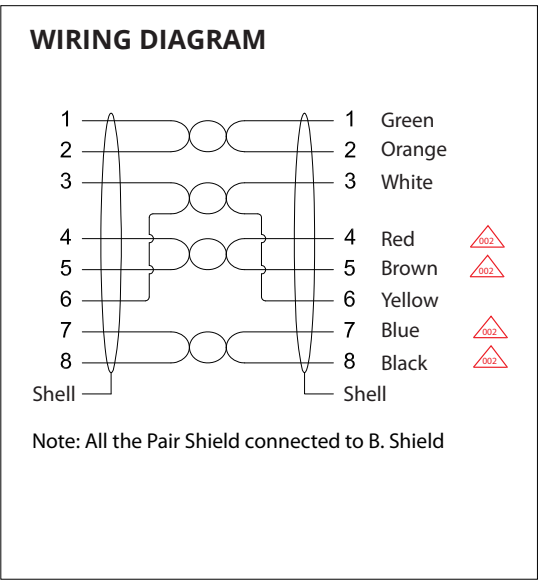

ACCESSORIES DETAILS

This Assembly/ Item ③ inclusive of accessories as per below shown:

- A) Metal Sheet Bracket (1pc)
- B) M2 Thumb Screw (2pcs)
- C) M2.6 x 2.5mm Flat Head Screw (1pc) (Pre-Installed in RJ45 connector)
- D) M2.6 x 5.0mm Flat Head Screw (1pc) (Use for install Metal Housing Bracket)
- E) Spacer (Thickness = 2 mm & 4mm) (Each 1pc)
- F) 90D Rear Hood (1pc)
- G) Hood Clip (1pc)



PLUG LENGTH & LOCKING BRACKET CUSTOMIZATION:

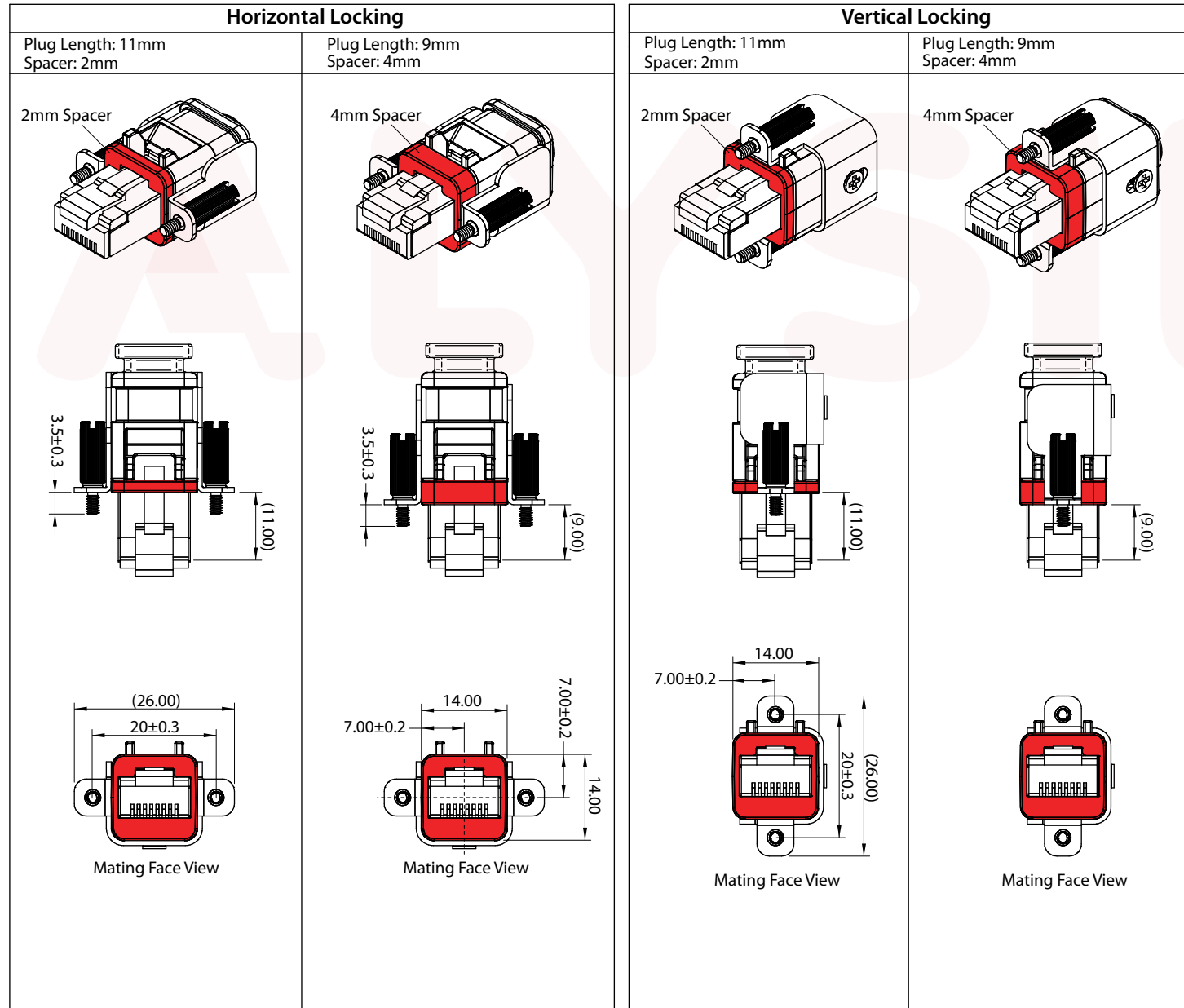

Bracket Installation Guide line

Step 1:
Remove rubber ring from the die cast body to reveal the threaded mounting hole

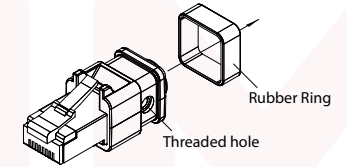

Step 2:
Determine the plug length required (9mm or 11mm) and insert the spacer to the plug from the front to depress on the latch tab

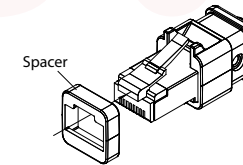

Step 3:
After spacer installation, glide the bracket from the back and fasten using M2.6 x 5.0mm screw provided

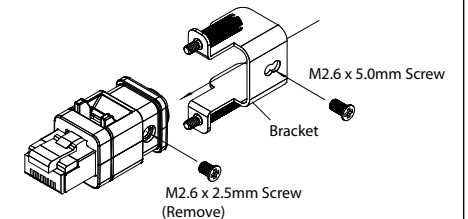

Step 4:
Customization/ installation completed
Same steps apply to horizontal bracket installation

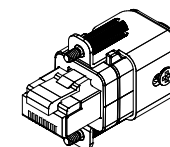



PLUG ORIENTATION CUSTOMIZATION:

A1 Direction

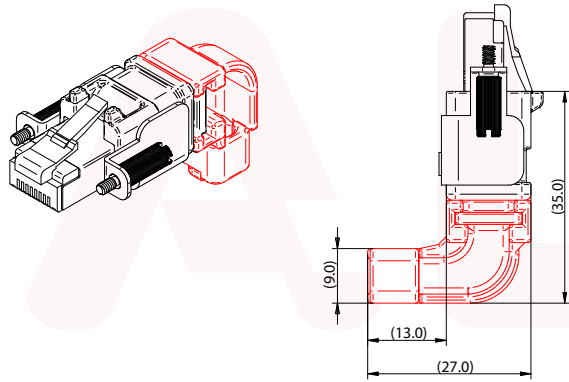

A3 Direction

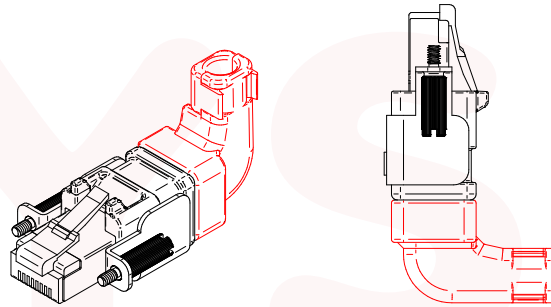

A2 Direction

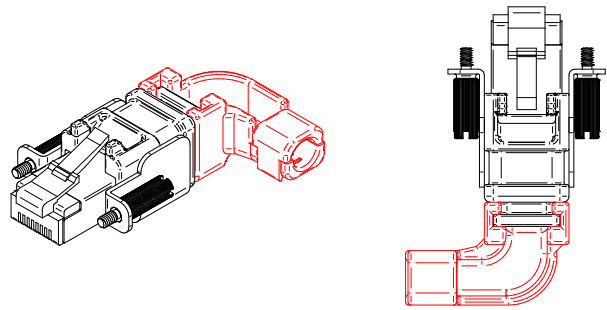

A4 Direction

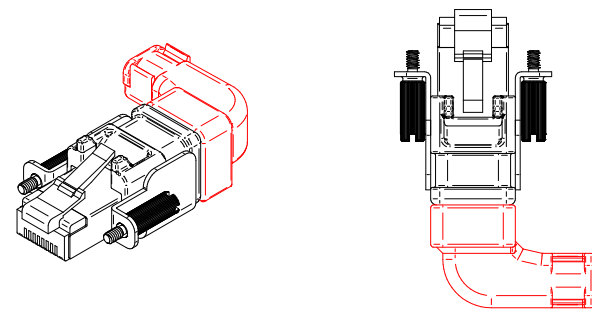

Rear Hood Installation Guide

Step1

- Decide desire connector orientation.
- Slot-in raw cable by follow trail shape (See Image 1)
- Insert and glide along Hood's groove.

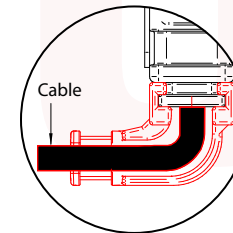
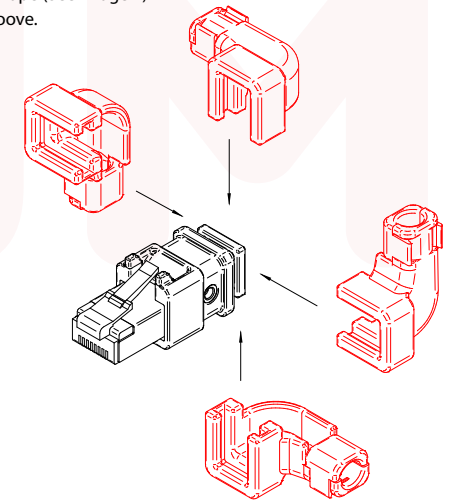
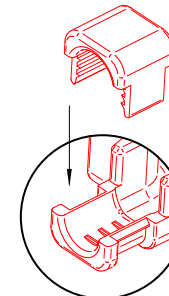

Image 1



Step 2

- Snap on by using given CLIP to secure raw cable firmly.





Heat Sealed PE Bag Packaging

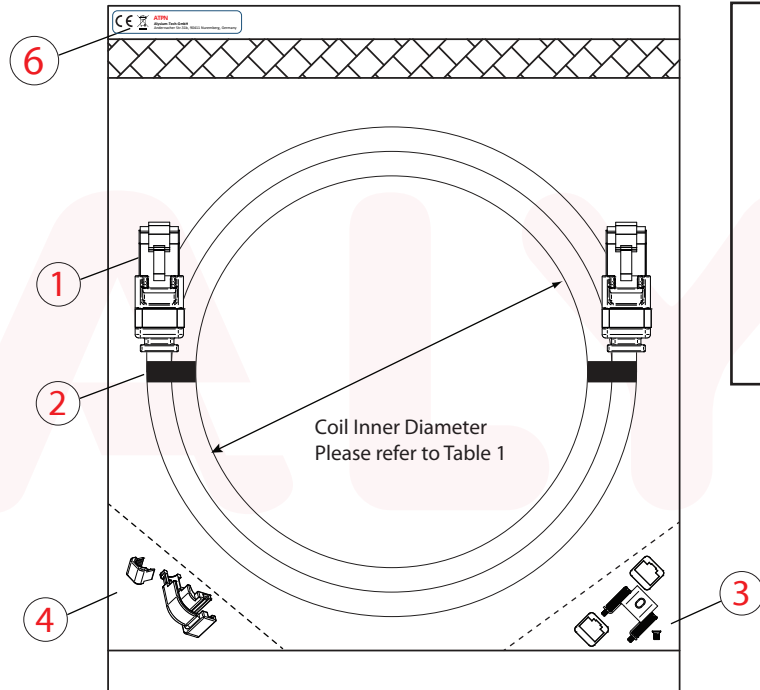

Cable Label Guideline

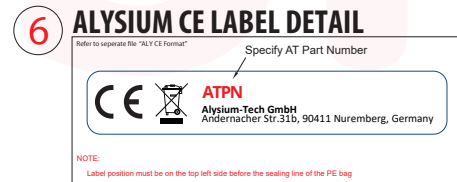
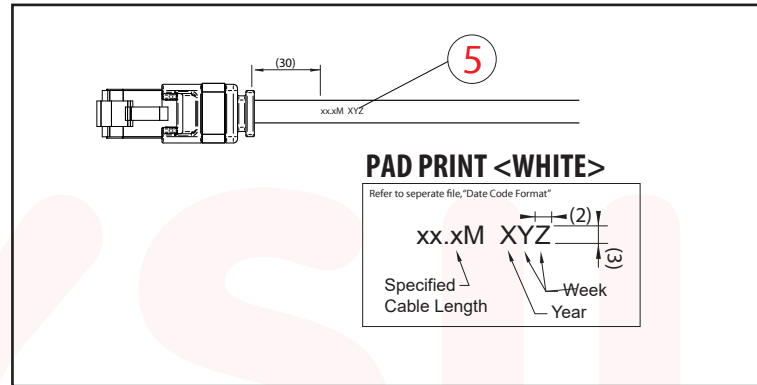

Packaging Contains

- | | |
|----------------------------------|------|
| 1) Basic Assembly | 1pc |
| 2) Magic Tie / Cable Tie | 2pcs |
| 3) Bracket Accessories | 1Set |
| --> Metal Sheet Bracket | 1pc |
| --> Thumb Screw (M2) | 2pcs |
| --> Spacer (Thickness =2mm) | 1pc |
| --> Spacer (Thickness =4mm) | 1pc |
| --> M2.6 x 5.0mm Flat Head Screw | 1pc |
| 4) 90D Rear Hood Accessories | 1Set |
| --> 90D Rear Hood | 1pc |
| --> Rear Hood Clip | 1pc |
| 5) White Pad Print | 1pc |
| 6) Label On Bag (ALY CE) | 1pc |

Table 1 : Assembly Coiling Inner Diameter
(Unless Otherwise)Specified

Type of Cable / Cable Jacket OD	Coil ID (mm)
General	250