



EVOLUTIONARY INTERCONNECTS

PIONEERS USE

ALYSIUM

WHY DO PIONEERS USE ALYSIUM?

We are restless, just like you! Great products can be always better, and innovation is relentless. Complacency is banished. It is our job to allow you to consistently achieve more, further increasing your competitive advantage through technical and commercial efficiencies. Addressing more with less, yet quicker as well. This is our enduring commitment to our customers and fellow pioneers!

A+
what you expect **+more**

- Continuous engineering innovation
- Enhanced product performance and reliability
- Your dependable, motivated partner

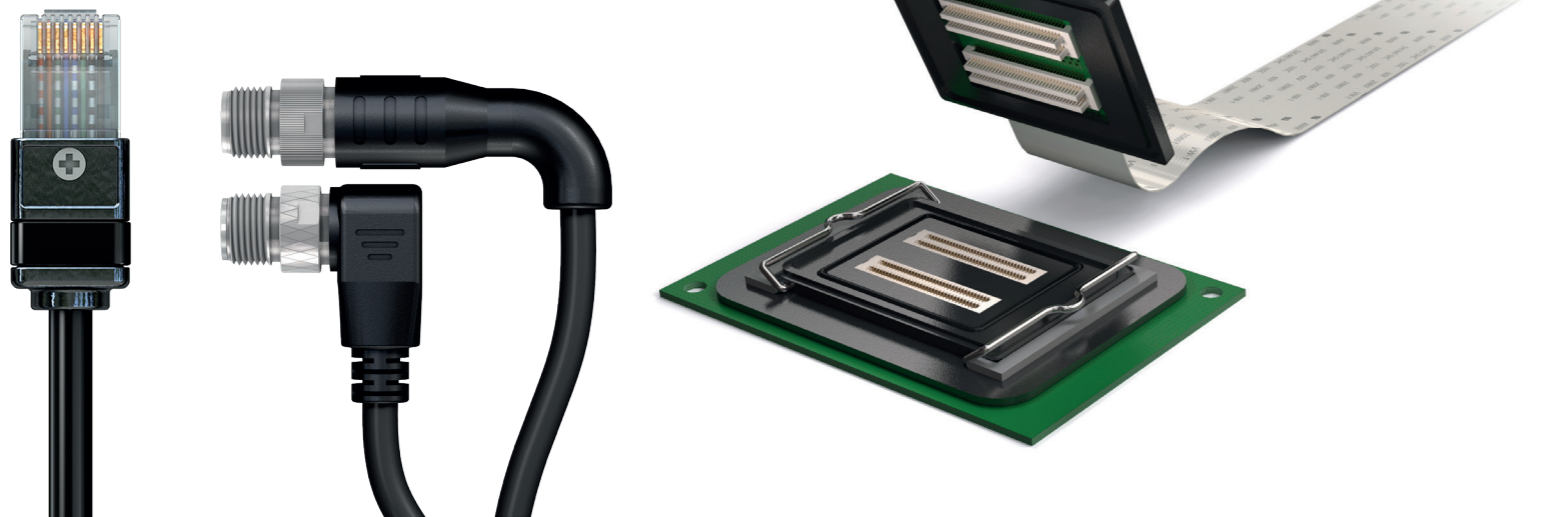

+more

More scope to enhance the performance of your products and systems, to increase your competitive advantage in the marketplace.

More suited to meet and exceed your performance requirements, which is our understanding of "what you expect + more".

More chance to successfully delegate all of your interconnect concerns / challenges, and allow you to focus on your primary business goals.

More chance to be positively surprised by what is technically possible, by harnessing the joy of innovation and technical market leadership.



ALYSIUM AT THE HEART OF YOUR SOLUTION

Leveraging Product Advantages at every Level.

Alysium's focus is on performance at every level of product inception. Enhanced raw cable capability is achieved through stable production processes and utilisation of optimal materials and is the foundation of the "+more" from your assemblies. Enhanced connector and termination technologies as both components and sub-components achieve higher density, more reliable and cost effective connection possibilities. Innovatively processing them together achieves assemblies that perform to a superior level.

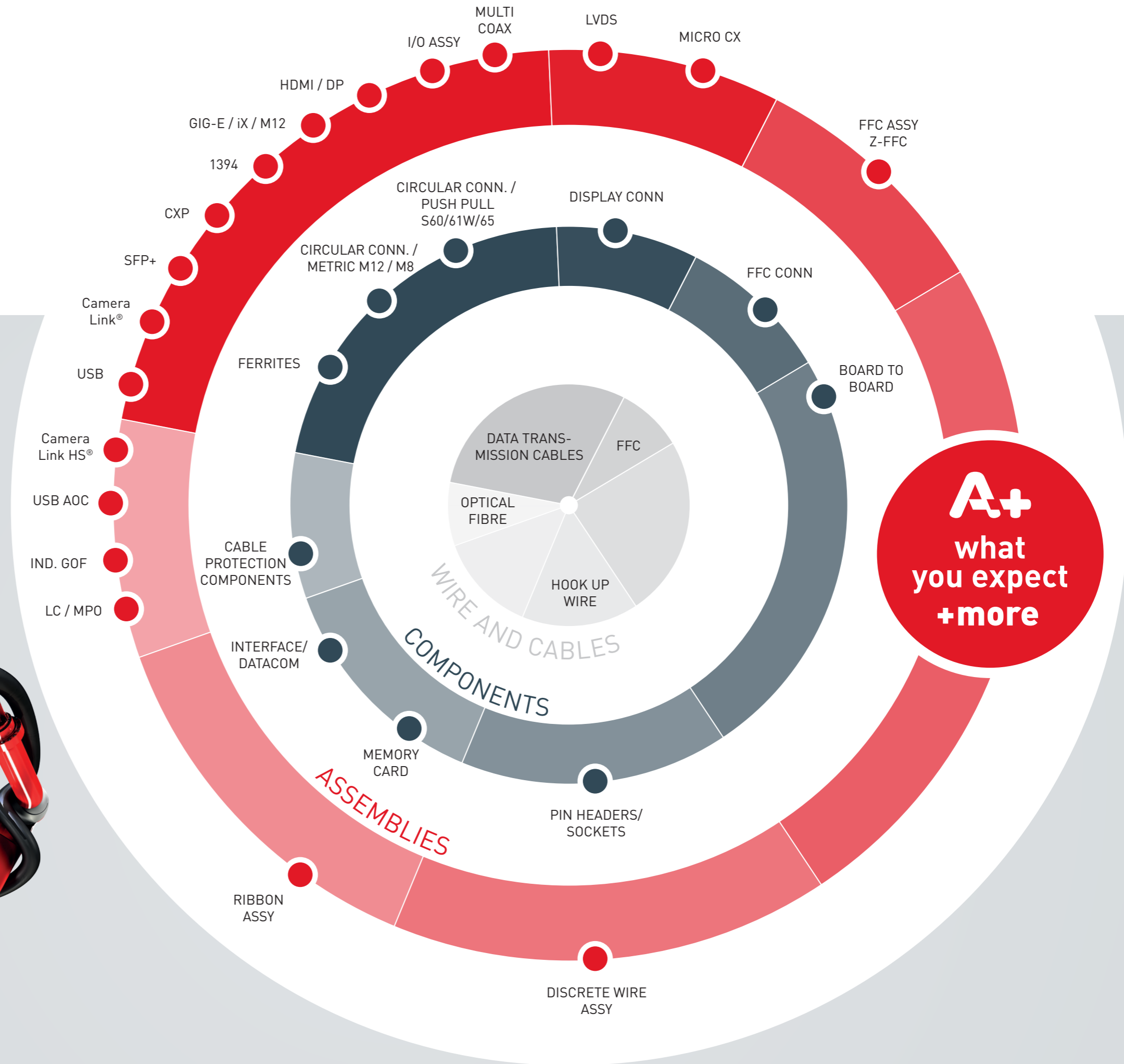

RELIABILITY PERFORMANCE INNOVATION TRUST

CASE STUDIES

RELIABILITY

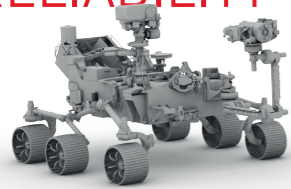

The Mars Rover successfully landed on Mars. Those wonderful landing images were transmitted through our assemblies.

PERFORMANCE



Mass production starts for fully autonomous Robots in retail, with Alysium inside!

INNOVATION



Life saving delivery of a defibrillator through specialised drone.

TRUST



On the moon connecting stereo cameras for Lunar Plume Surface Studies (SCALPSS).

TODAY

Your demanding project!

Your Partner for Progress

We support numerous industries that expect exceptional and durable system performance and / or design flexibility, and this in the context of continuous improvement. Staying at the cutting edge requires embracing details and seeking optimisations together at every juncture.

Let's keep pushing...

CUSTOMIZATION

ALYSIUM ADAPTIVE ASSEMBLIES

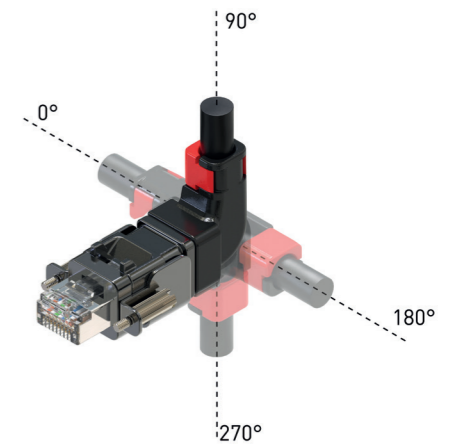

Our **Adaptive Assemblies** ensure that you always have the correct part available. Less inventory, no lead times, demand consolidated regardless of project requirements. It's the future, available now.

„It is not the strongest of the species that survives, nor the most intelligent; it is the one most responsive to change.“
Charles Darwin

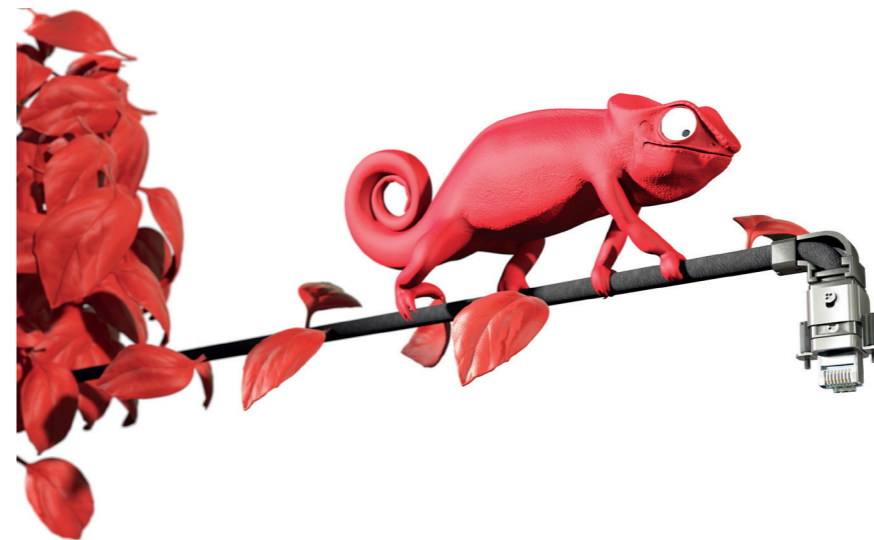

CUSTOMIZED AS INDIVIDUAL AS YOUR IDEAS

Utilizing design experience, material knowledge and production competence, coupled with a deep understanding of your requirements, we can build the missing piece of your application puzzle. Let's find the optimal solution together.

- REQUIREMENT DEFINITION
- CONCEPT PROPOSAL
- EVT SAMPLES
- QUALIFICATION
- SERIES PRODUCTION
- SUCCESS**

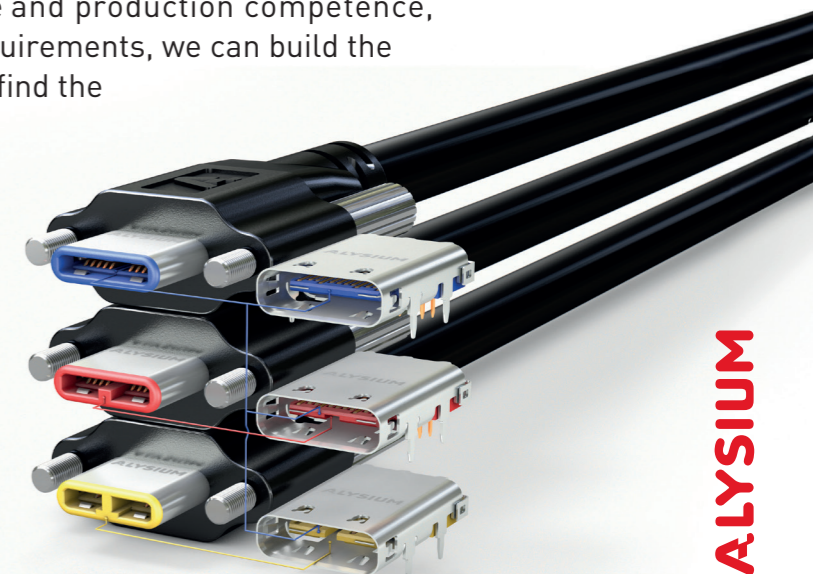

ALYSIUM

ALYSIUM

AUTOMOTIVE INTERCONNECTS

The automotive markets of human-machine interface (HMI), advanced driver-assistance systems (ADAS) and electric vehicle (EV) systems are experiencing exciting times!

The support to our customers is unwavering to ensure we remain at the forefront of these developments, by offering a range of cutting-edge automotive products and

services that leverage the latest innovation in material and production technologies. Our specialities are lamination technologies, metal stamping and moulding processes, to realise superior products. They are available as single components or integrated into assemblies, specifically tailored to a given specification, and ready to be mounted as part of a subassembly module.

Laminated Cables

- FFC (Flat Flexible Cable)
- Airbag Cable
- Jumper Cable

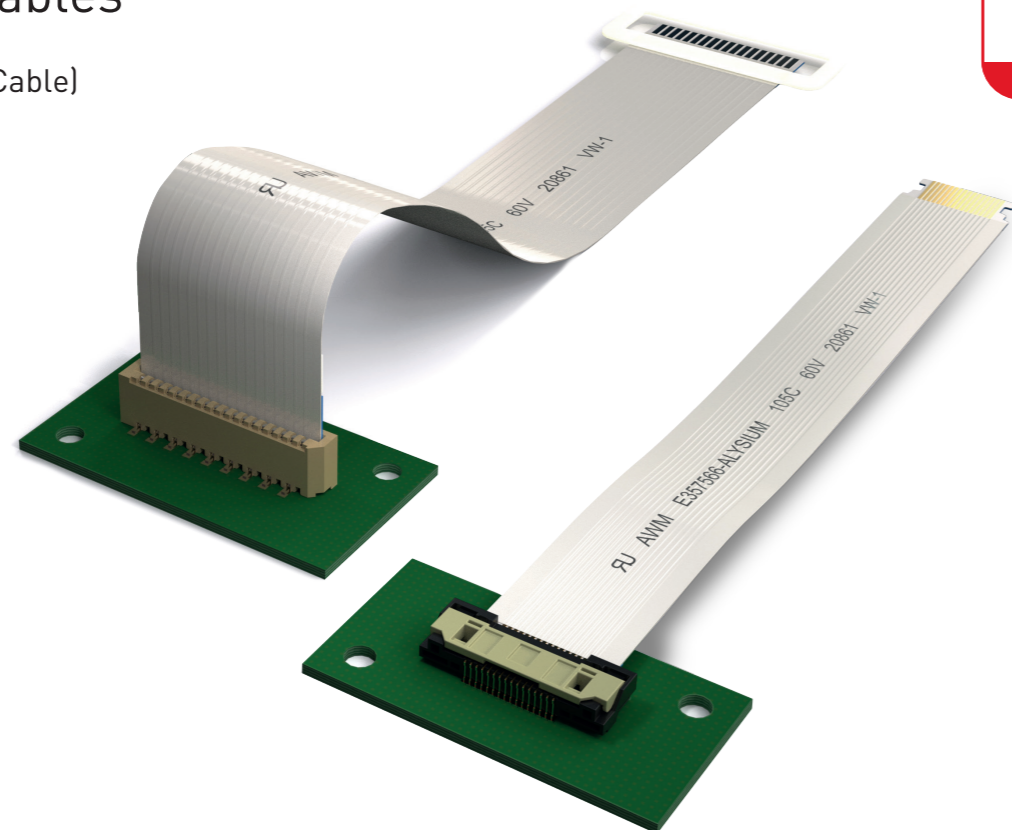

Connector Solutions

- FFC / FPC Connector (LIF, ZIF, Autolock)
- Floating Board to Board
- Detachable Connectors

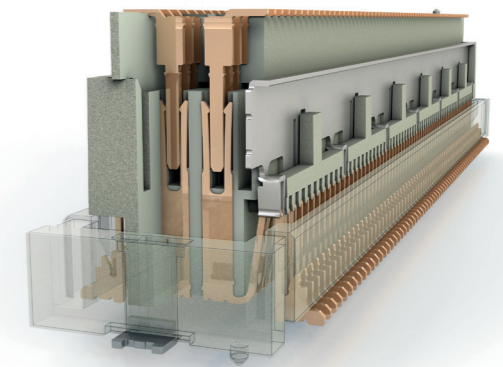

Customers select Alysium as their preferred supplier based on the following factors:

- **Quality:** Complete quality-driven production process and control
- **Reliability:** IATF 16949:2016 facility certification / VDA 6.3 / PPAP / PSW
- **Innovation:** Enhanced raw material and product tolerances
- **Customer Services:** Exceptional project development support
- **Reputation:** Greater than 20 years of successful collaboration with Tier 1 companies
- **Sustainability:** EN ISO 14001:2015 facilities certification and "green focus"

+more

Assemblies

- FAKRA (Fachkreis Automobil)
- Wire to Board
- Custom Solutions

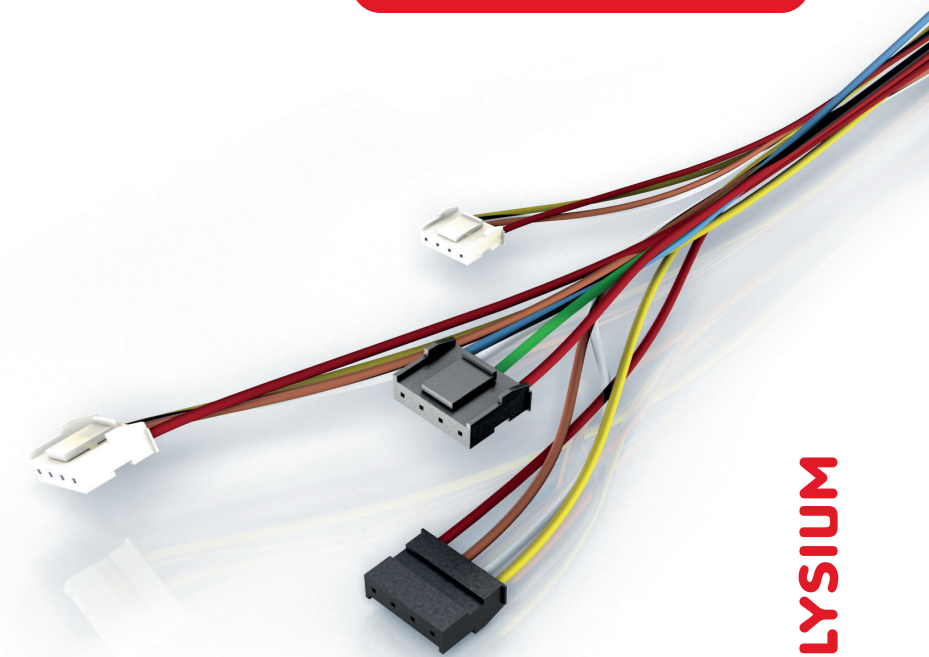

INDUSTRIAL

Industrial requirements can be found in all facilities used for producing, processing or assembling goods; factory automation, logistics, food and beverage, textiles, pharmaceutical... the list goes on. All share the expectation of reliability, durability and performance.

Industrial applications can demand high flex products suitable for C-track or robotic arm installation, or high speed data transmission, or harsh application environments. Alysium delivers interconnects for IO and data transmission that enhance the operation and reliability for your systems.



MACHINE VISION

Industrial Machine Vision assemblies have been our passion since the company's founding. Providing reliable, exceptional products that offer more length, more space, more durability, or simply put, more options to you, to enhance the performance of your vision system.

Working with market leaders to ensure that cutting edge products are also supported with the best interconnects, ensuring that your requirements of tomorrow are already being manufactured today!

OPTICAL ASSEMBLIES

Alysium utilized the knowledge and expertise gained from years of experience in industrial cabling to create our range of Active Optical Assemblies. Increases in data rates, coupled with the expectations of high flex performance in longer cable lengths demanded the use of durable and reliable AOC assemblies to overcome the limitation of copper based cables. Fiber cabling is much less bulky than copper,

offers excellent flex-life and is immune to electrical noise. Pure optical assemblies can also offer galvanic isolation for medical applications. Our stocked active optical assemblies support the latest standards, such as USB3.2 10G or Camera Link HS@. Passive optical assemblies, terminated with as examples, LC and MPO are also supported for industrial applications.

HIGHLIGHTS:

- Die-Cast Industrial connector
- 360 degrees EMI shielding
- Extended lengths
- Terminations with unique screw lock brackets (design protected)
- Plug and Play Operation

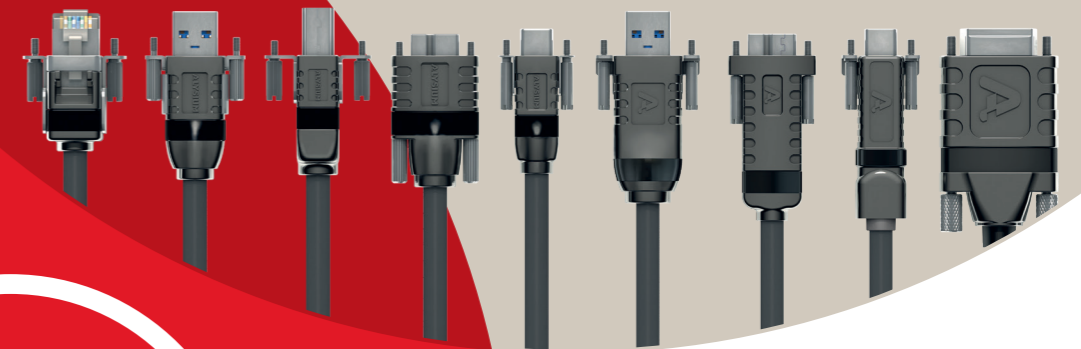



ALYSIUM

Europe

Andernacher Strasse 31b
90411 Nuremberg
Germany

T +49 [0] 911 93 78 78 0

North America

480 University Avenue
Suite 1500
Toronto, M5G 1V2, Ontario
Canada

T +1 416 598 7120

South-East Asia

Oasis Square Ara Damansara
Ara Damansara PJU 1A
47301 Petaling Jaya
Selangor Malaysia
Malaysia

T +603 7832 6889

sales@alysium.com

www.alysium.com

